

UNDERFLOOR HEATING - GLUE SYSTEM

Commercial / Residential

UNDERFLOOR HEATING

E 4.0	General Information
E 4.3	Glue Down System Information

GENERAL INFORMATION

These instructions apply to Junckers solid floors glued to a subfloor with built-in underfloor heating.

It should be noted that for full information, document E 4.0 should also be taken into account, see Fig. 1.

Fig. 1

GLUE DOWN SYSTEM WITH EMBEDDED HEATING PIPES OR CABLES

Junckers Glue Down system can be applied to a concrete or screeded subfloor with embedded heating pipes or cables. It is extremely important to design the underfloor heating system in such a way as to achieve a regular temperature distribution across the top surface of the subfloor.

Regular temperature distribution is achieved at a pipe/cable embedding depth of min. 30 mm and a pipe spacing of 300 mm c/c or a cable spacing of 150 mm c/c.

Before commencing the installation of the flooring, the temperature and humidity of the building should correspond to the expected future climatic conditions of the building when in use, e.g. 35-65% relative humidity, approx. 20°C, see C 1.0. This may be achieved by operating the underfloor heating system to the extent necessary, according to circumstances. During this period, the building should be ventilated briefly every day.

In concrete and screeded subfloors, etc., with embedded underfloor heating systems, the residual humidity in the concrete or screed must not exceed 65% relative humidity which is measured by correct instrumentation, see C 1.3. In order to reach the required maximum relative humidity, the heating system must have been both commissioned and in operation. If the residual moisture content is higher than recommended Junckers Liquid Moisture Barrier, see H 6.5, must be used. During installation, the underfloor heating system must be turned off to aid glue workability.

COMPONENTS

1 - Boards

- Junckers 14 and 22 mm 2-strip boards, incl. ships decking
- Junckers 15 and 20.5 mm Planks, incl. ships decking.

2 - Glue

- Junckers Parquet Glue

3 - Concrete or screeded subfloor

4 - Heating pipes/cables

5 - Reinforcement

6 - Insulation

7 - Structural concrete floor

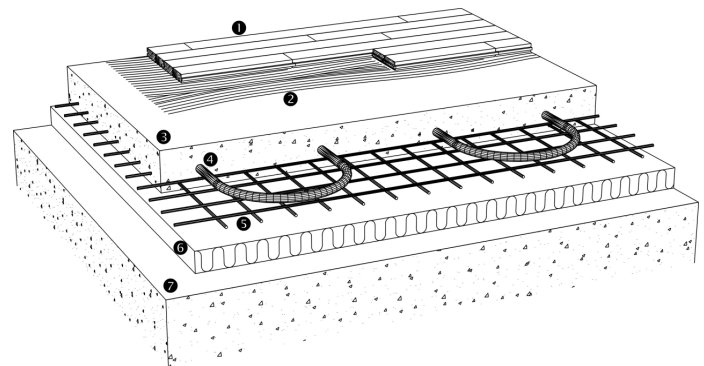

Fig. 3

Fig. 2

GLUE DOWN SYSTEM ON CONCRETE WITH HEATING CABLE

Junckers Glue Down system can be applied to a concrete subfloor with an embedded heating cable mat. It is extremely important to design the underfloor heating system in such a way as to achieve a regular temperature distribution across the top surface of the subfloor.

In order to protect the heating cables and ensure a regular heat distribution, the heating cable mat must be covered by a cementitious layer, min. 6 mm thick. Before installing the heating mat, the subfloor may need to be primed to ensure that the mat adheres correctly to the base.

When renovating floors where the heating system is placed on an existing, dry subfloor, the Glue Down System can be applied as soon as the cementitious layer is fully dry. Follow the directions of the manufacturer.

When placing the heating cable mats on a new concrete floor, flooring can commence when the temperature and humidity of the building correspond to the expected future climatic conditions of the building when in use, e.g. 35-65% relative humidity, approx. 20°C, **see C 1.0**. This may be achieved by operating the underfloor heating system to the extent necessary according to circumstances. During this period, the building should be ventilated briefly every day.

In concrete subfloors, etc., with embedded underfloor heating systems, the residual humidity of the concrete must not exceed 65% relative humidity which is measured by correct instrumentation, **see C 1.3**. In order to reach the required maximum relative humidity, the heating system must have been both commissioned and in operation. If the residual moisture content is higher than recommended **Junckers Liquid Moisture Barrier**, **see H 6.5**, must be used.

During installation, the underfloor heating system must be turned off to aid glue workability.

COMPONENTS

1 - Boards

- Junckers 14 and 22 mm 2-strip boards, incl. ships decking
- Junckers 15 and 20.5 mm Planks, incl. ships decking.

2 - Glue

- Junckers Parquet Glue

3 - Cementitious layer

- min. 6 mm

4 - Heating cable mat

5 - Structural concrete floor

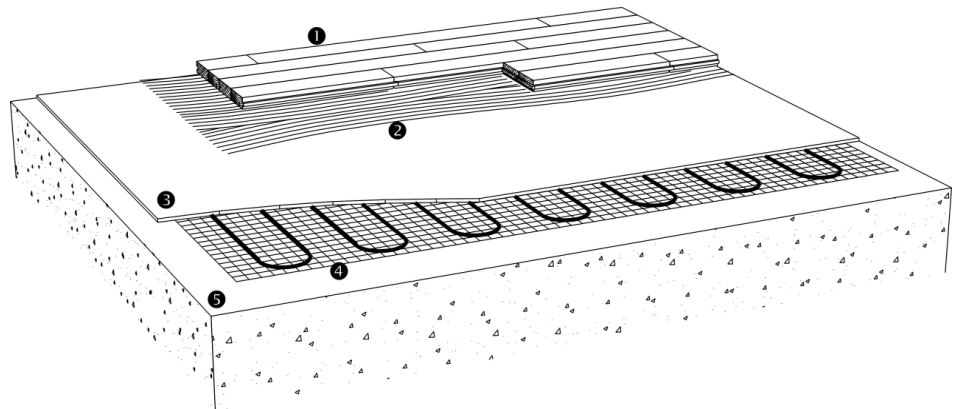

Fig. 5

Fig. 4